

SEQUE PELA MONTAGEM DE CONSUMÍVEL PVC  
 RECOLETE: LIGAÇÃO RESERVATÓRIO INTERIOR, QUAJ. PVC  
 LA - LUBA ESCVA LIVRE ALIBRI DO PISO  
 COM TELA INDEFORMÁVEL NYLON  
 ASS. INCLINADO  
 SEQUE PELA ALIMENTAÇÃO DO BOILER  
 CORTES  
 ESC. 1:50

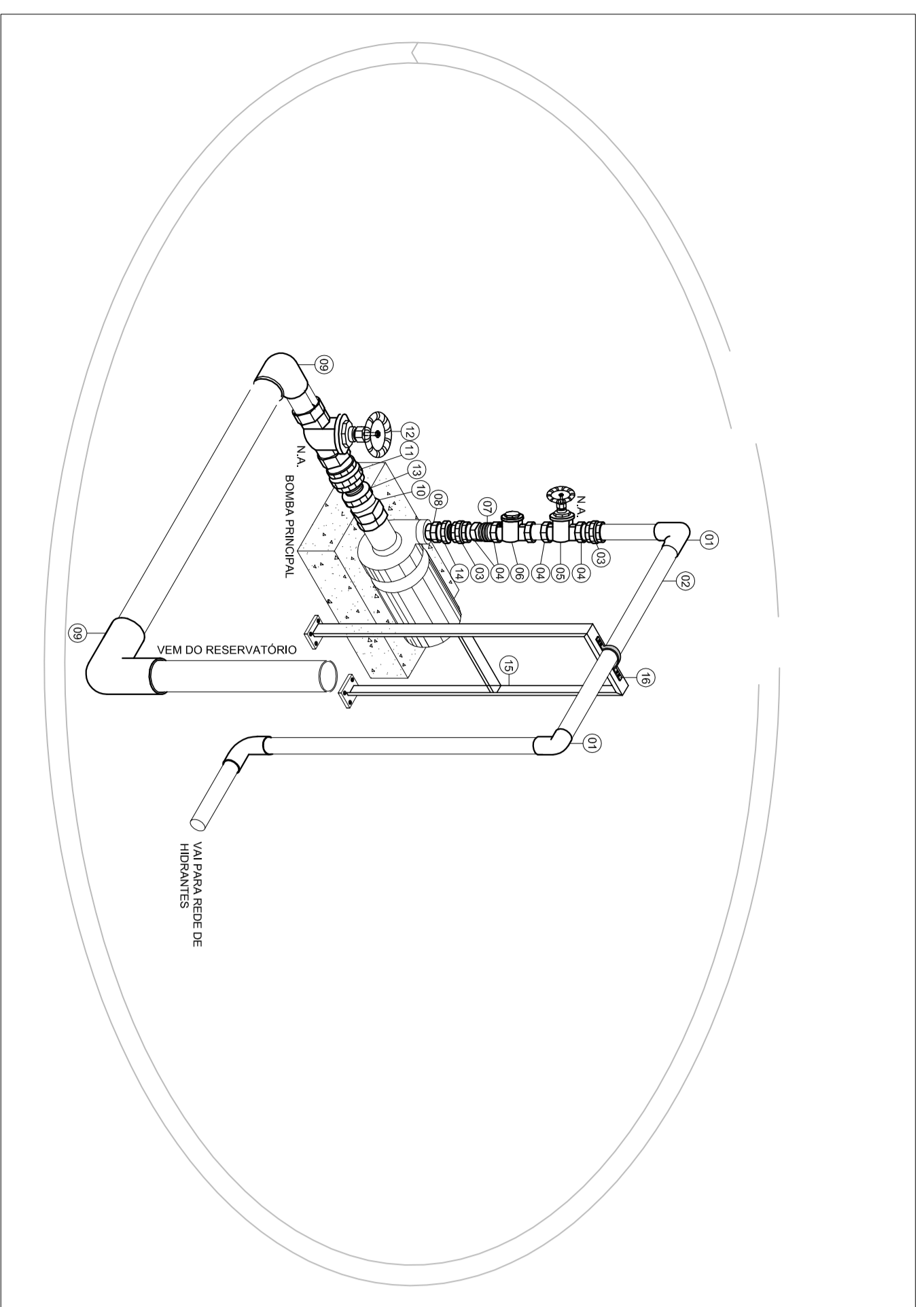

ITEM	BOMBA DE INCÊNDIO	SÍMBOLO COM
01	DESTINO DE - FOGOS - 8"	8"
02	TAMPA - FOGOS - 8"	8"
03	TAMPA - FOGOS - 8"	8"
04	TAMPA - FOGOS - 8"	8"
05	TAMPA - FOGOS - 8"	8"
06	TAMPA - FOGOS - 8"	8"
07	TAMPA - FOGOS - 8"	8"
08	TAMPA - FOGOS - 8"	8"
09	TAMPA - FOGOS - 8"	8"
10	TAMPA - FOGOS - 8"	8"
11	TAMPA - FOGOS - 8"	8"
12	TAMPA - FOGOS - 8"	8"
13	TAMPA - FOGOS - 8"	8"
14	TAMPA - FOGOS - 8"	8"
15	TAMPA - FOGOS - 8"	8"
16	TAMPA - FOGOS - 8"	8"

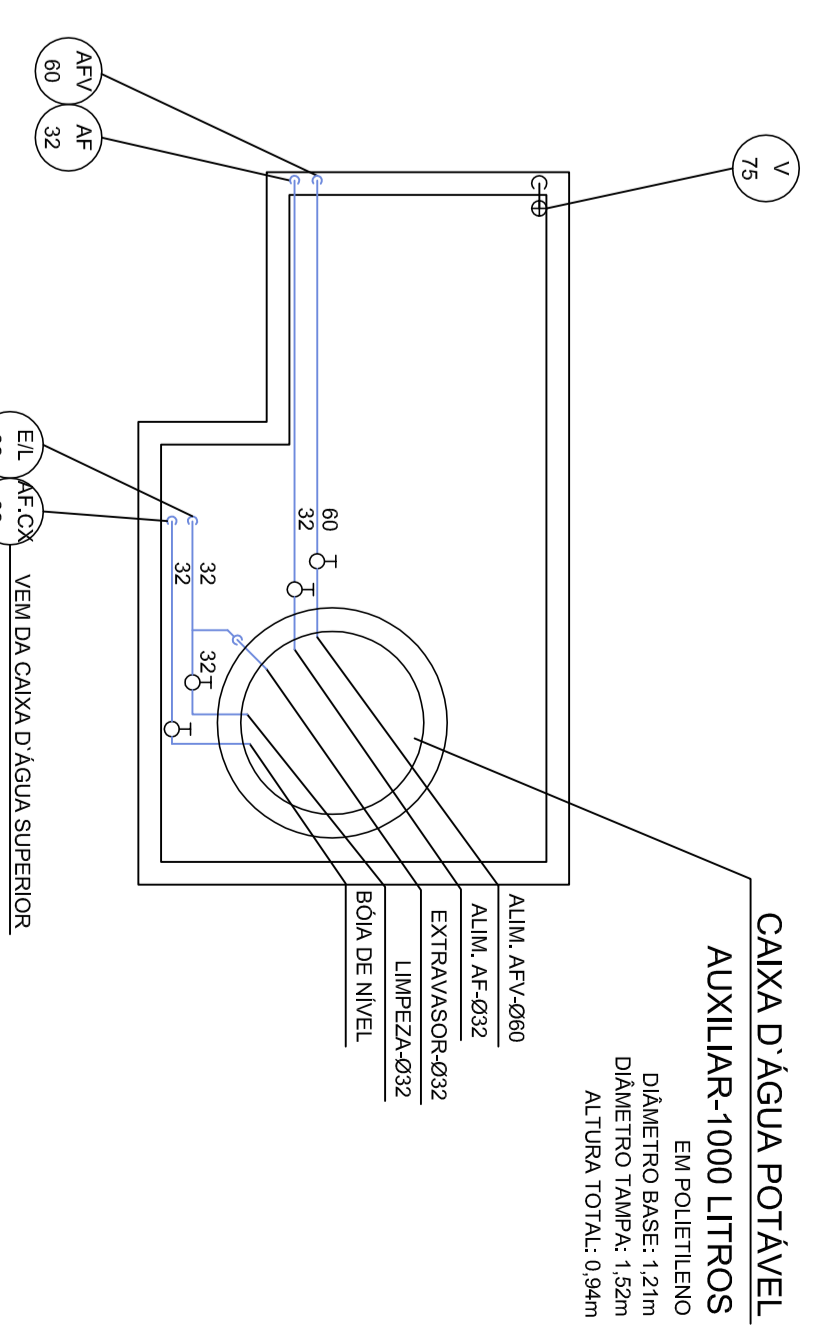
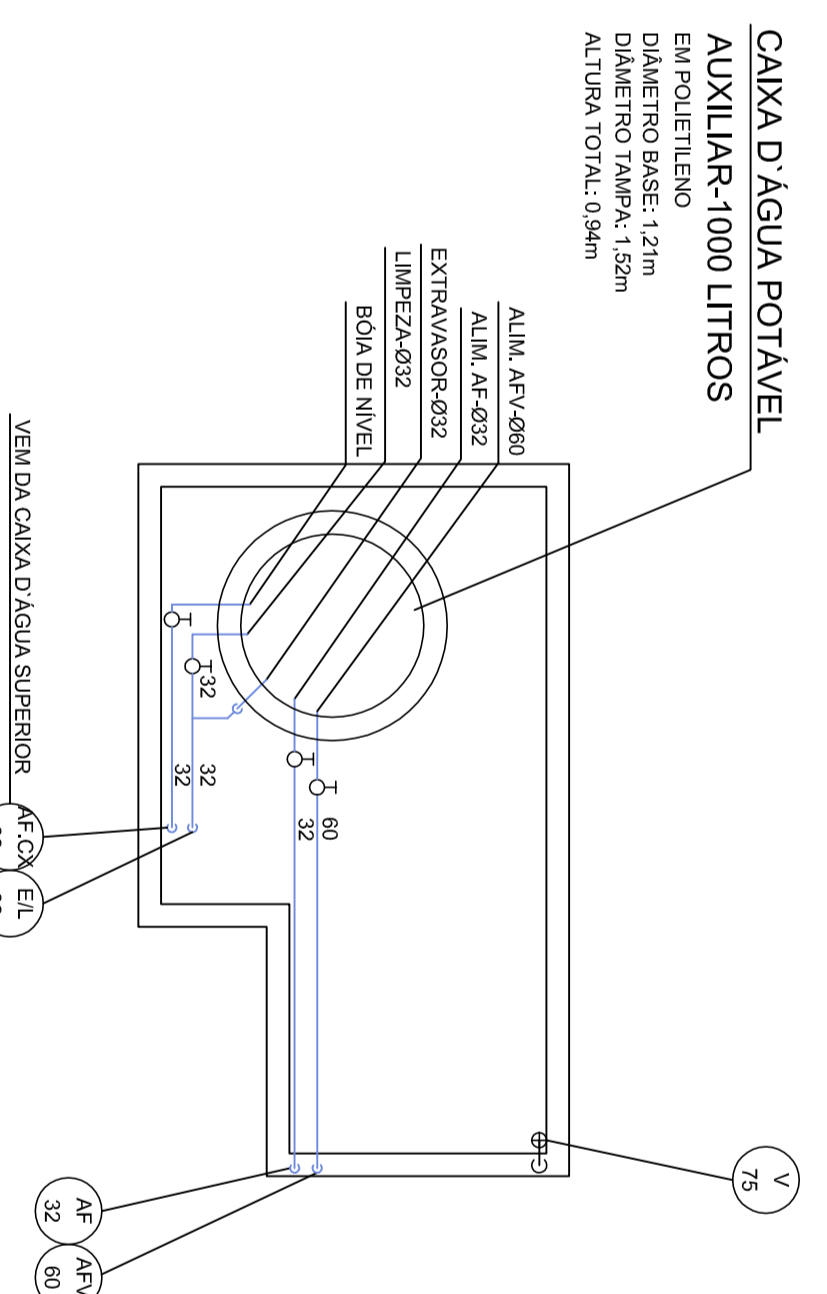
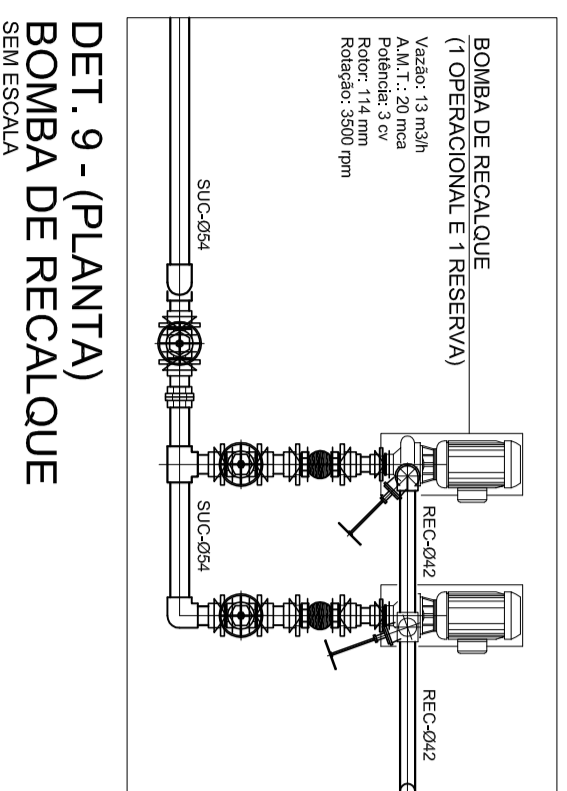
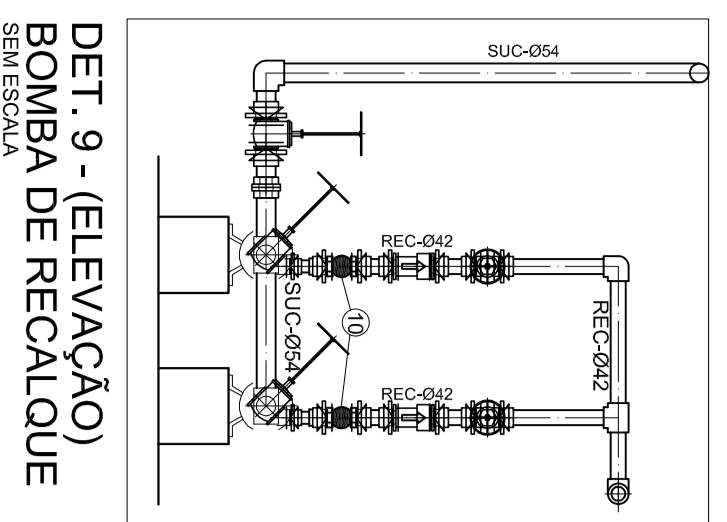
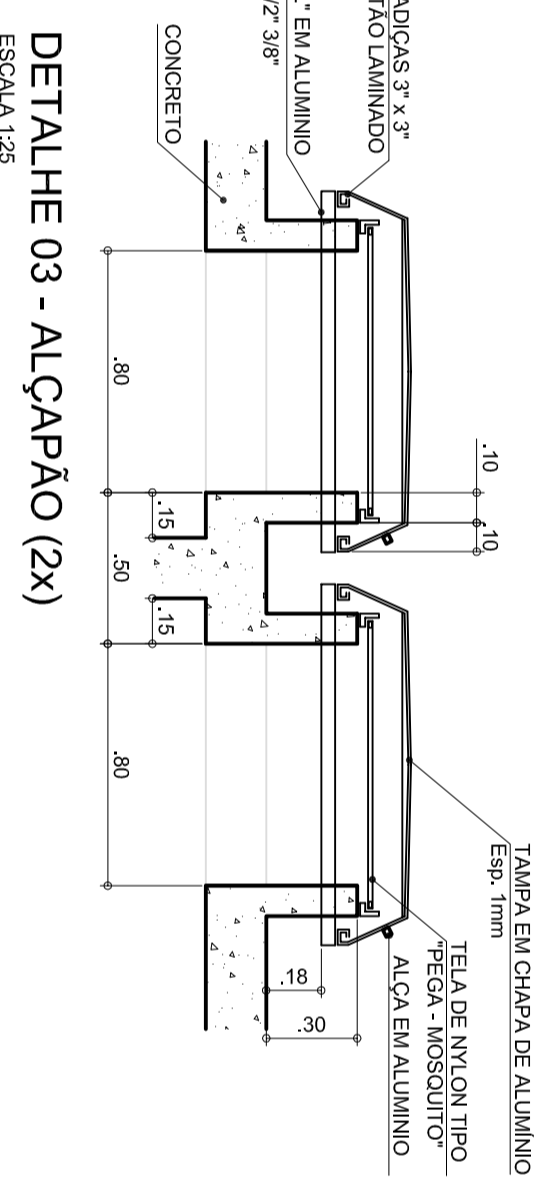
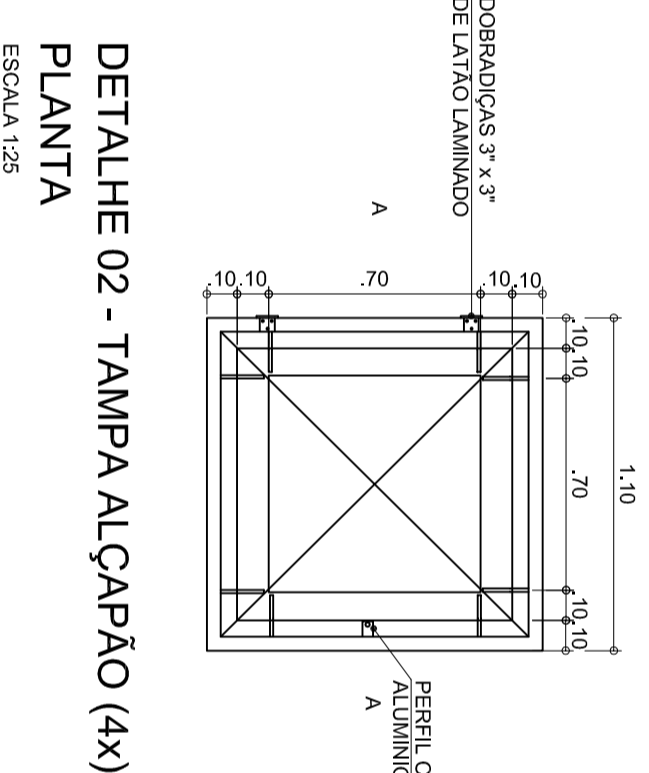

TIPO	REQUISITO	SITUAÇÃO		OBSERVAÇÃO
		REQUISITO	RESPOSTA	
1	REQUISITO 1	<input type="checkbox"/>	<input type="checkbox"/>	
2	REQUISITO 2	<input type="checkbox"/>	<input type="checkbox"/>	
3	REQUISITO 3	<input type="checkbox"/>	<input type="checkbox"/>	
4	REQUISITO 4	<input type="checkbox"/>	<input type="checkbox"/>	
5	REQUISITO 5	<input type="checkbox"/>	<input type="checkbox"/>	
6	REQUISITO 6	<input type="checkbox"/>	<input type="checkbox"/>	
7	REQUISITO 7	<input type="checkbox"/>	<input type="checkbox"/>	
8	REQUISITO 8	<input type="checkbox"/>	<input type="checkbox"/>	
9	REQUISITO 9	<input type="checkbox"/>	<input type="checkbox"/>	
10	REQUISITO 10	<input type="checkbox"/>	<input type="checkbox"/>	
11	REQUISITO 11	<input type="checkbox"/>	<input type="checkbox"/>	
12	REQUISITO 12	<input type="checkbox"/>	<input type="checkbox"/>	
13	REQUISITO 13	<input type="checkbox"/>	<input type="checkbox"/>	
14	REQUISITO 14	<input type="checkbox"/>	<input type="checkbox"/>	
15	REQUISITO 15	<input type="checkbox"/>	<input type="checkbox"/>	
16	REQUISITO 16	<input type="checkbox"/>	<input type="checkbox"/>	